



**BUILDING DEPARTMENT
350 CITY HALL SQUARE W.
WINDSOR ON
N9A 6S1
WWW.CITYWINDSOR.CA**

CONSTRUCTION GUIDE FOR DECKS



TABLE OF CONTENTS

What do I need to know before starting?	3
What do I need to submit for a building permit?	3
What is the cost of a building permit?	3
STEP 1 – What is the zoning of my property?	4
How do I find my zoning information?	4
What is the height of the deck and where can I build it?.....	4
STEP 2 – What size deck do I want to build?	6
Draw a site plan.....	6
STEP 3 – What layout should I use?	7
Layout A	7
Layout B	8
Layout C	9
Layout D	10
STEP 4 – What type of footing am I going to use?	11
STEP 5 – Layout my deck	12
Draw a custom deck layout	12
Example Deck Framing Plan.....	13
Custom Deck Layout.....	14
STEP 6 – How am I attaching the deck to the house?	15
STEP 7 – What guards and railings are required?	16
After I get my permit what inspections are required?	17
Required During All Inspections	17
Required Inspections	17
How to Schedule an Inspection	17
Additional Information	18
Glossary of Terms	18

WHAT DO I NEED TO KNOW BEFORE STARTING?

Please note that although a building permit may not be required, you must still comply with the City of Windsor Zoning By-law and Ontario Building Code requirements.

The information contained within this pamphlet is intended as a guide for Do-It-Yourself deck projects. It is designed for basic decks and includes member sizing and construction details.

Please note that member sizes contained within may be greater than the minimum sizes identified in the Ontario Building Code. This is due to the use of general sizes in the pre-designed deck layouts.

All lumber within 6" of grade must be pressure treated to resist decay.

For decks that are outside of the general layouts within this guide, you will be required to submit a custom design or a design from a B.C.I.N. Qualified Designer.

If you have any questions or concerns contact the Building Department for more information at:

- buildingdept@citywindsor.ca
- 519-255-6267

WHAT DO I NEED TO SUBMIT FOR A BUILDING PERMIT FOR A DECK?

- Complete application through Cloudpermit at <https://ca.cloudpermit.com/>
- Site Plan - A site plan identifies buildings and other features in relation to property boundaries. It should identify the location of your existing house, other existing structures (ie. garages, sheds, decks) and the proposed construction
- Deck Layout – use the enclosed layouts and tables to select appropriate sizes for the structural members of the proposed deck. Provide a plan showing the layout of the proposed deck with the selected structural members labelled. Included within the layouts are (1) example layout highlighting the required information to apply for a permit and (1) sheet of graph paper for designing a custom layout.
- Select footing detail, beam connection detail and attachment detail to house from the details provided.

Note: If the proposed design does not comply with the tables and details provided in this package then a full submission of plans and details will be required for review. Please contact the Building Department for further information.

- Along with the documents/plans listed above, other approvals may be required for your particular project. The following are some approvals that may be required upon submitting your application prior to issuance of a building permit.
 - ERCA
 - Septic Sewage System Approval
 - Ministry of Transportation
 - Additional permits or approvals

WHAT IS THE COST OF A BUILDING PERMIT

The following is the standard fees that apply:

Construction Permit Fee	\$0.90/sf (min \$265)
Zoning Fee	\$55
GIS User Fee	7% of the building permit total

Some fees may vary. For a complete fee schedule please go to the City of Windsor web site at www.citywindsor.ca

Please note: Fees as of **MARCH 1, 2024** and are **subject to change** upon Council approval.

STEP 1 – WHAT IS THE ZONING OF MY PROPERTY?

How do I find my Zoning Information?

Go to the City of Windsor website for Public Property Inquiries at <https://publicpropertyinquiry.citywindsor.ca/> You can search for your property by street address or Roll Number. In the Property Details tab look for the line Zone 1. This will tell you the zoning of your property. (ex. RD1.2)

ZONING DESIGNATION: _____

With your Zoning designation you can find your required yards in the City of Windsor Zoning By-law 8600. Go to the City of Windsor website at www.citywindsor.ca. Under the tab City Hall go to By-laws Online.

REQUIRED YARDS AS PER THE ZONING BY-LAW

MINIMUM FRONT YARD (a): _____

MINIMUM SIDE YARD (b): _____

MINIMUM REAR YARD (c): _____

NOTE: If you have questions about your zoning information please contact the Building Department.

What is the height of the deck and where can I build it?

Deck heights are measured from the lowest point of the ground to the top of the deck floor. A deck with a height up to including 12" (300mm) do not require a permit but must still comply with the City of Windsor Zoning By-law and Ontario Building Code requirements.

**If an existing yard depth or existing yard width is less than that required, the maximum encroachment into that yard shall be measured from the closest wall of the main building facing that yard.

Uncovered Deck and Steps 1'-0" (0.3m) or less above ground

Permitted into a:

- (a) required front yard with no limit
- (b) required side yard with no limit
- (c) required rear yard with no limit

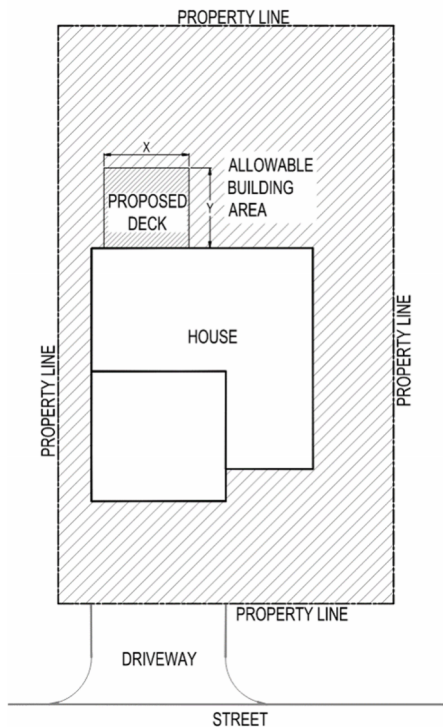

Uncovered Deck Greater than 1'-0" (0.3m) and less than 4'-0" (1.2m) above ground

Permitted into a:

- (a) required front yard a maximum of 8'-2" (2.50m) and a minimum of 4'-0" (1.2m) from the front lot line
- (b) required side yard with a minimum of 4'-0" (1.2m) from the side lot line
- (c) required rear yard with a minimum of 4'-0" (1.2m) from the rear lot line

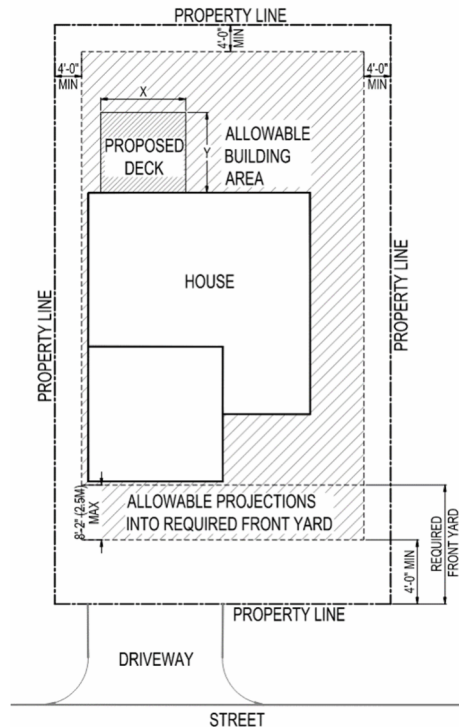

Uncovered Deck Greater than 4'-0" (1.2m) above ground

Permitted into a:

- (a) front yard a maximum of 8'-2" (2.50m) and a minimum of 4'-0" (1.2m) from the front lot line
- (b) not permitted in a side yard
- (c) required rear yard a maximum of 8'-2" (2.50m) and a minimum of 4'-0" (1.2m) from the rear lot line

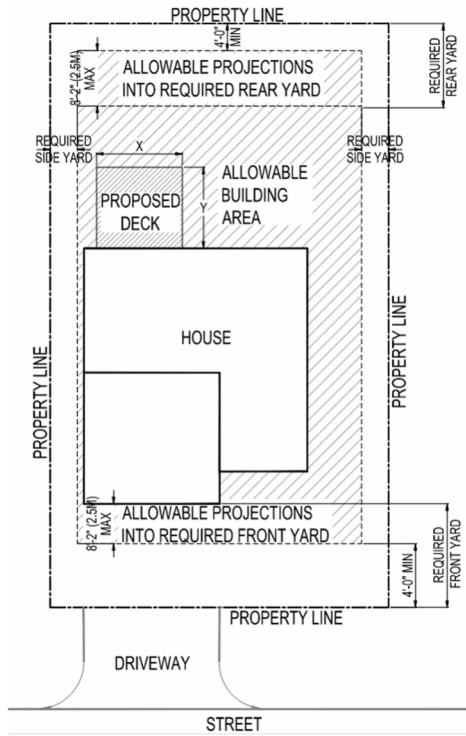

Steps Greater than 1'-0" (0.3m) above ground

Permitted into a:

- (a) required front yard with a minimum of 4'-0" (1.2m) from the front lot line
- (b) required side yard with a minimum of 4'-0" (1.2m) from the side lot line
- (c) required rear yard with a minimum of 4'-0" (1.2m) from the rear lot line

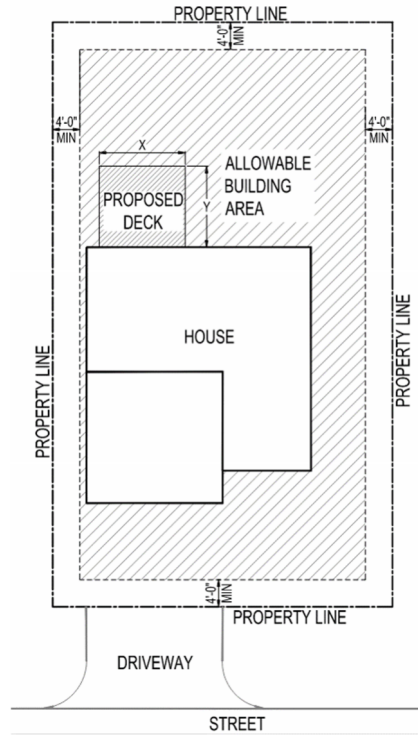

Townhome Dwelling Units - Uncovered Deck Greater than 1'-0" (0.3m) and less then 4'-0" (1.2m) above ground

Permitted into a:

- (a) required front yard a maximum of 8'-2" (2.50m) and a minimum of 4'-0" (1.2m) from the front lot line
- (b) required side yard with a minimum of 4'-0" (1.2m) for decks in the front yard. No minimum separation from the interior side lot line is required for decks in the side or rear yard.
- (c) required rear yard with a minimum of 4'-0" (1.2m)

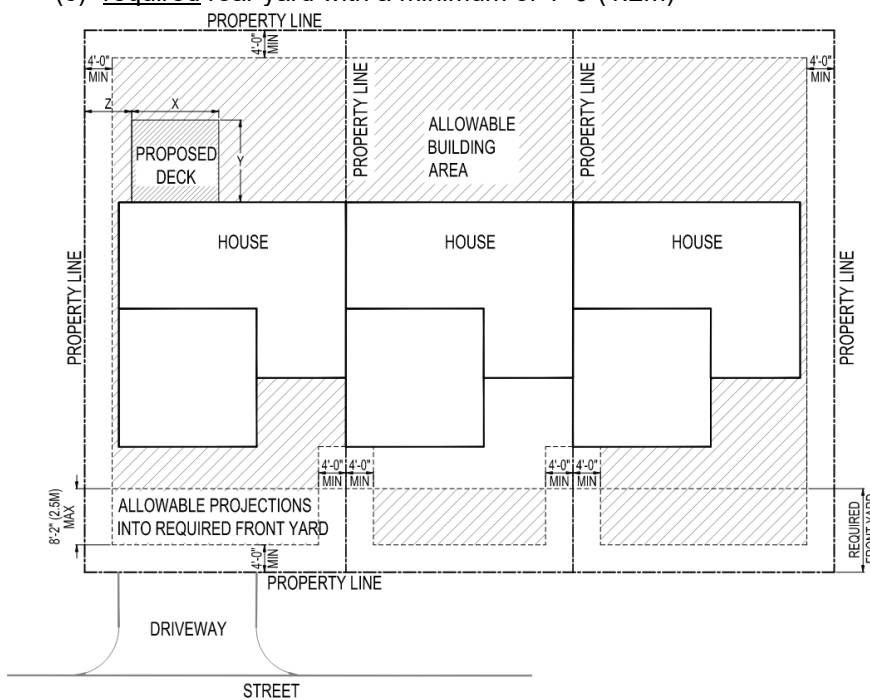

STEP 2- WHAT SIZE DECK DO I WANT TO BUILD?

Draw a site plan, taking into consideration the zoning restrictions

Be sure to:

- identify the location of your existing house and other existing structures (ex. garages, sheds) in relation to the property boundaries with dimensions
- show the proposed deck and steps with dimensions
- label the street and property lines
- any easements

Tip: Use the sample drawings enclosed in this guide as a reference to see the kind of quality and detail we look for in drawings.

CUSTOM SITE PLAN

Use this page to draw your own site plan. Call out all required items. All plans must comply with the OBC & City regulations.

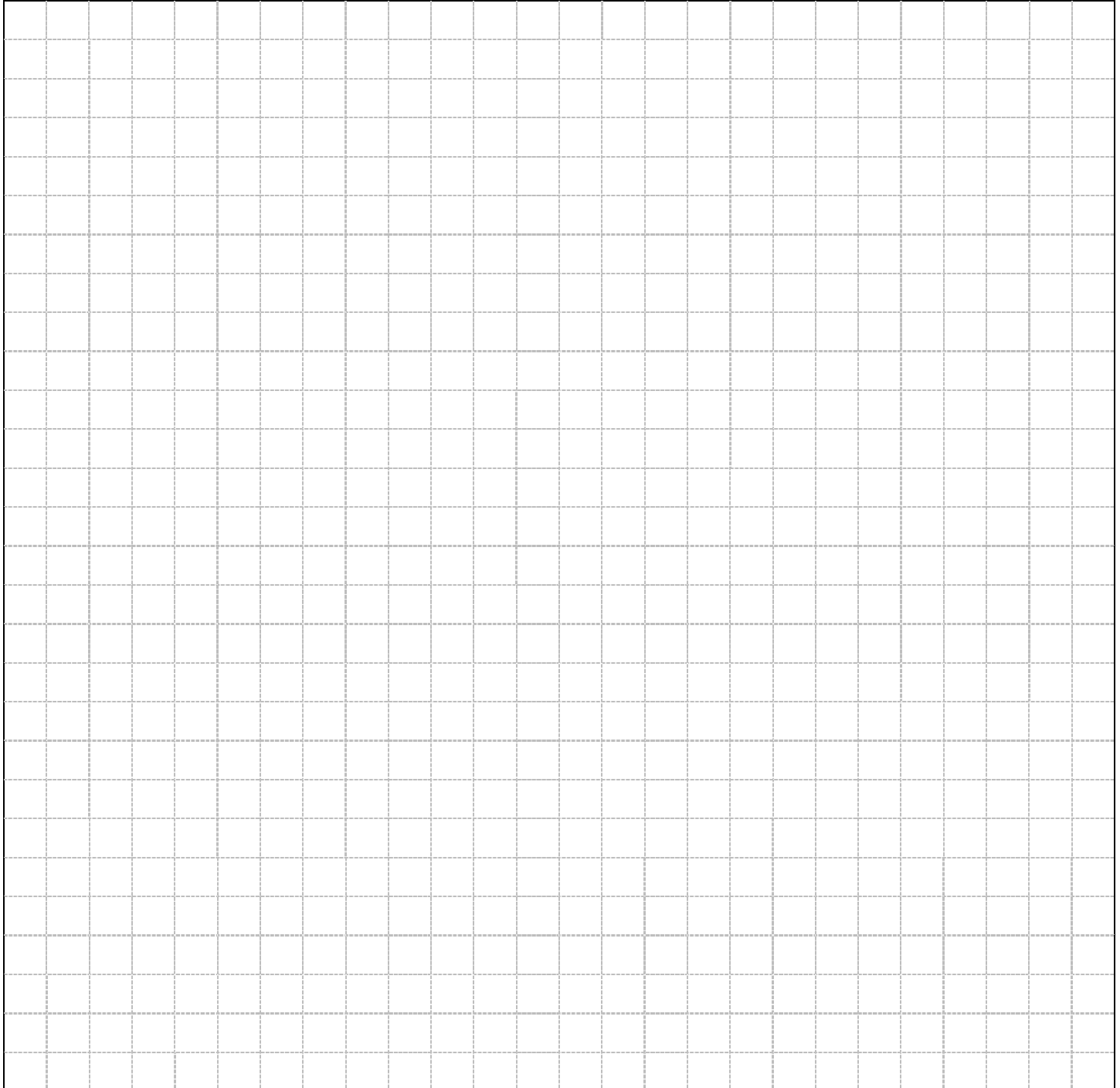

STEP 3 - WHAT LAYOUT SHOULD I USE?

Up to and including 8'x8'	Layout A
Over 8'x8' up to and including 12'x12'	Layout B
Over 12'x12' up to and including 14'x14'	Layout C
Over 14'x14' up to and including 16'x16'	Layout D
Over 16'x16'	A custom design or a design from a B.C.I.N. Qualified Designer.

**For decks that are outside of the general layouts within this guide, you will be required to submit a custom design or a design from a B.C.I.N. Qualified Designer

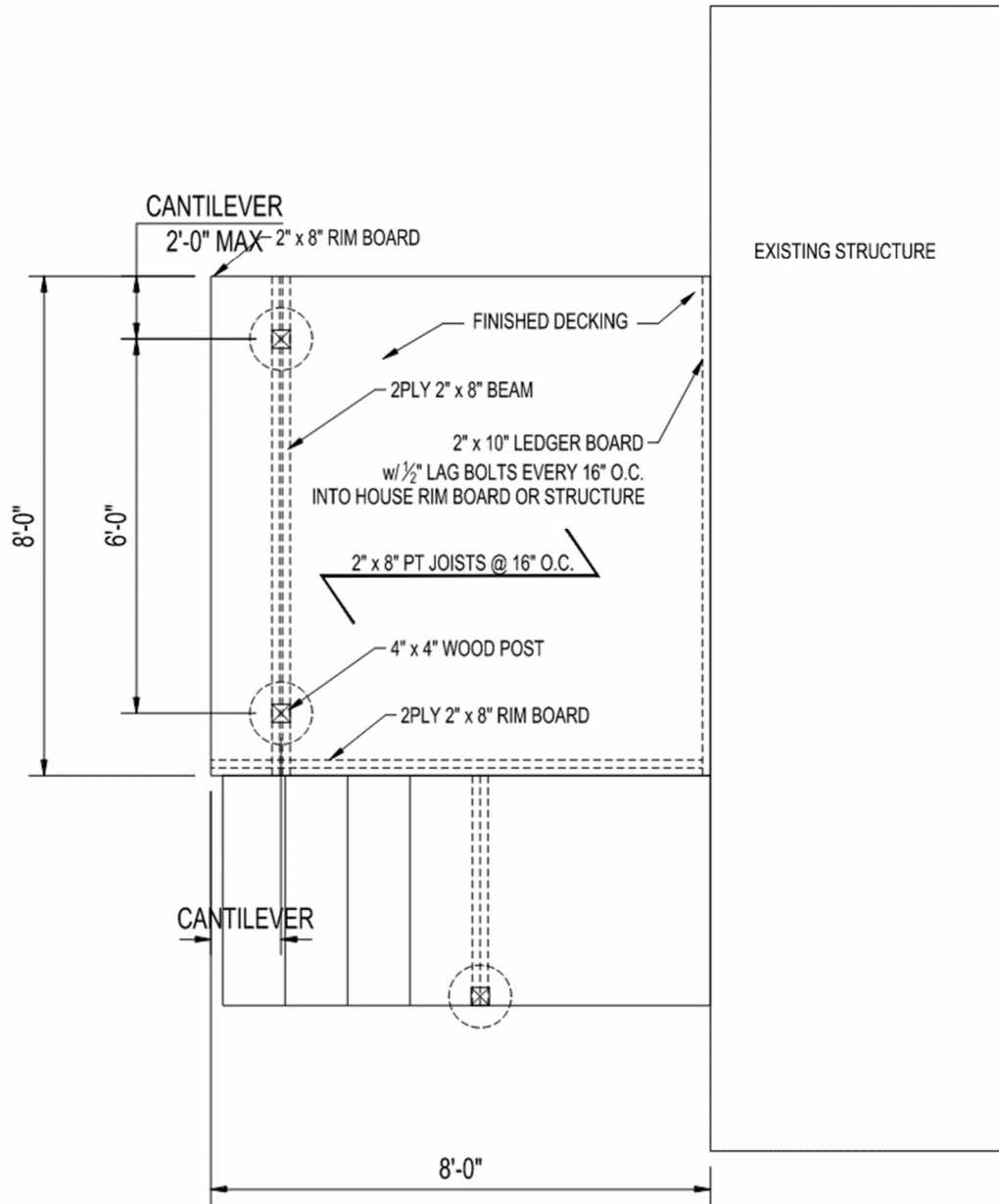

A - UP TO 8'x8' DECK FRAMING PLAN

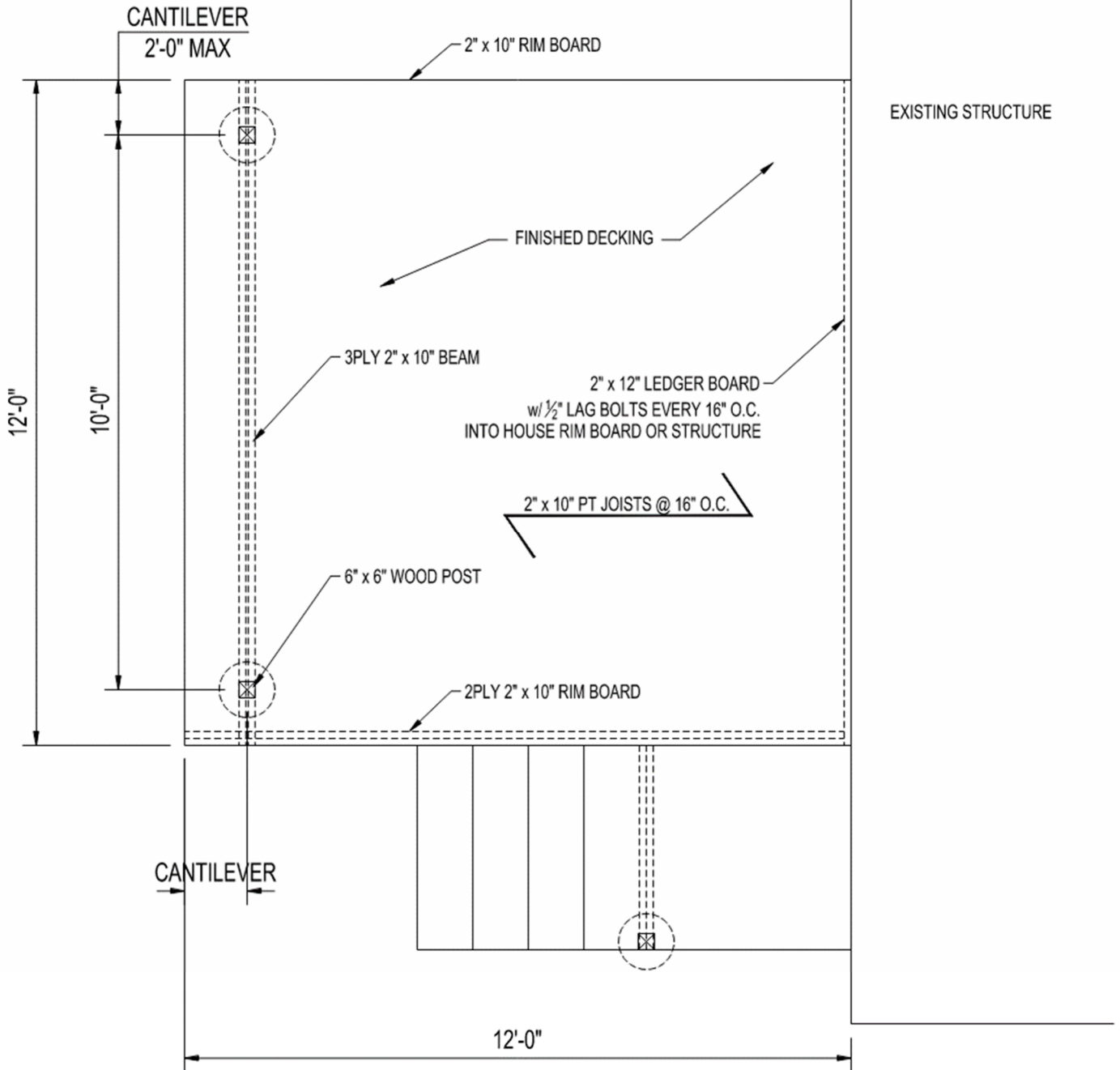

B - UP TO 12'x12' DECK FRAMING PLAN

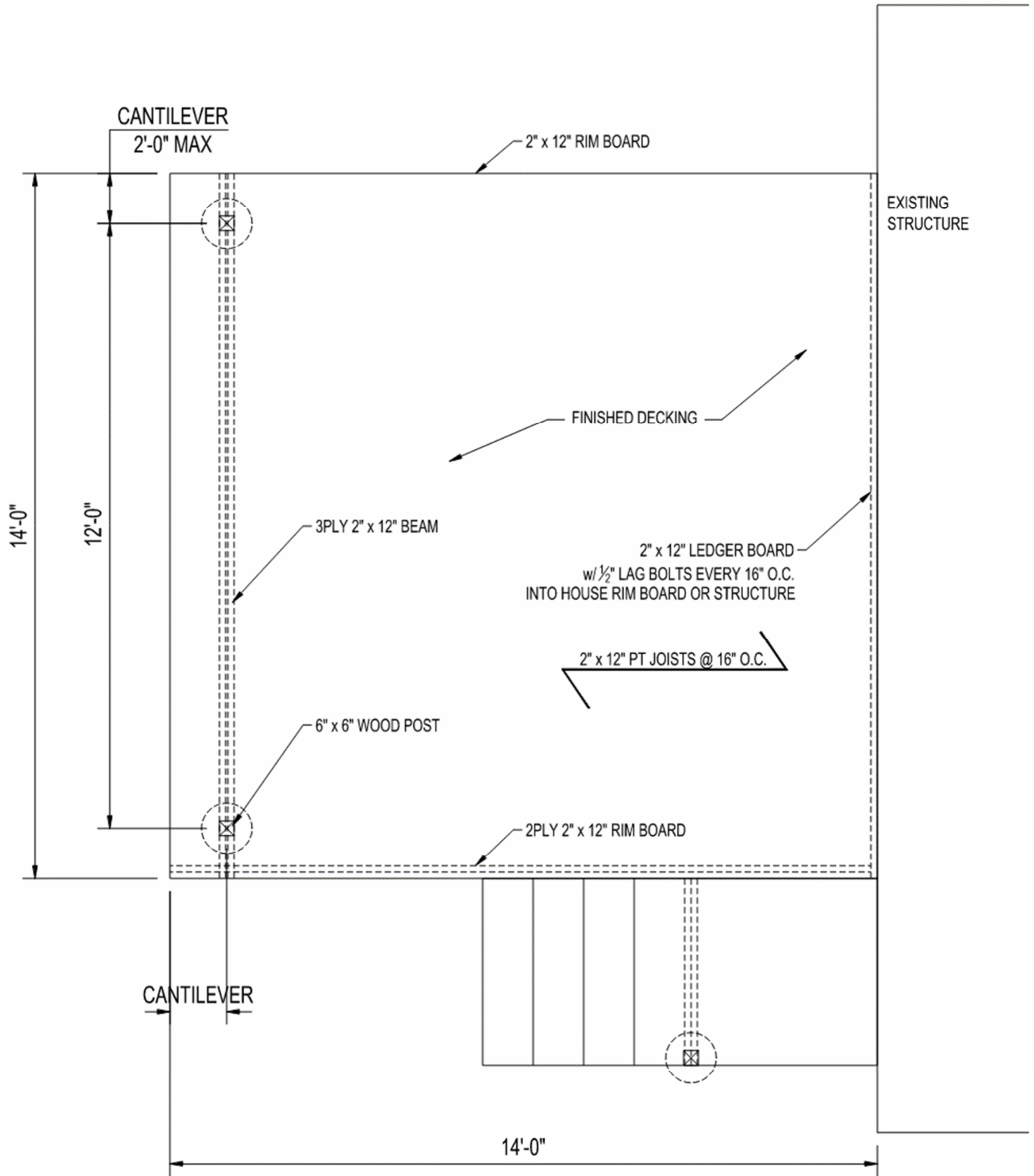

C - UP TO 14'x14' DECK FRAMING PLAN

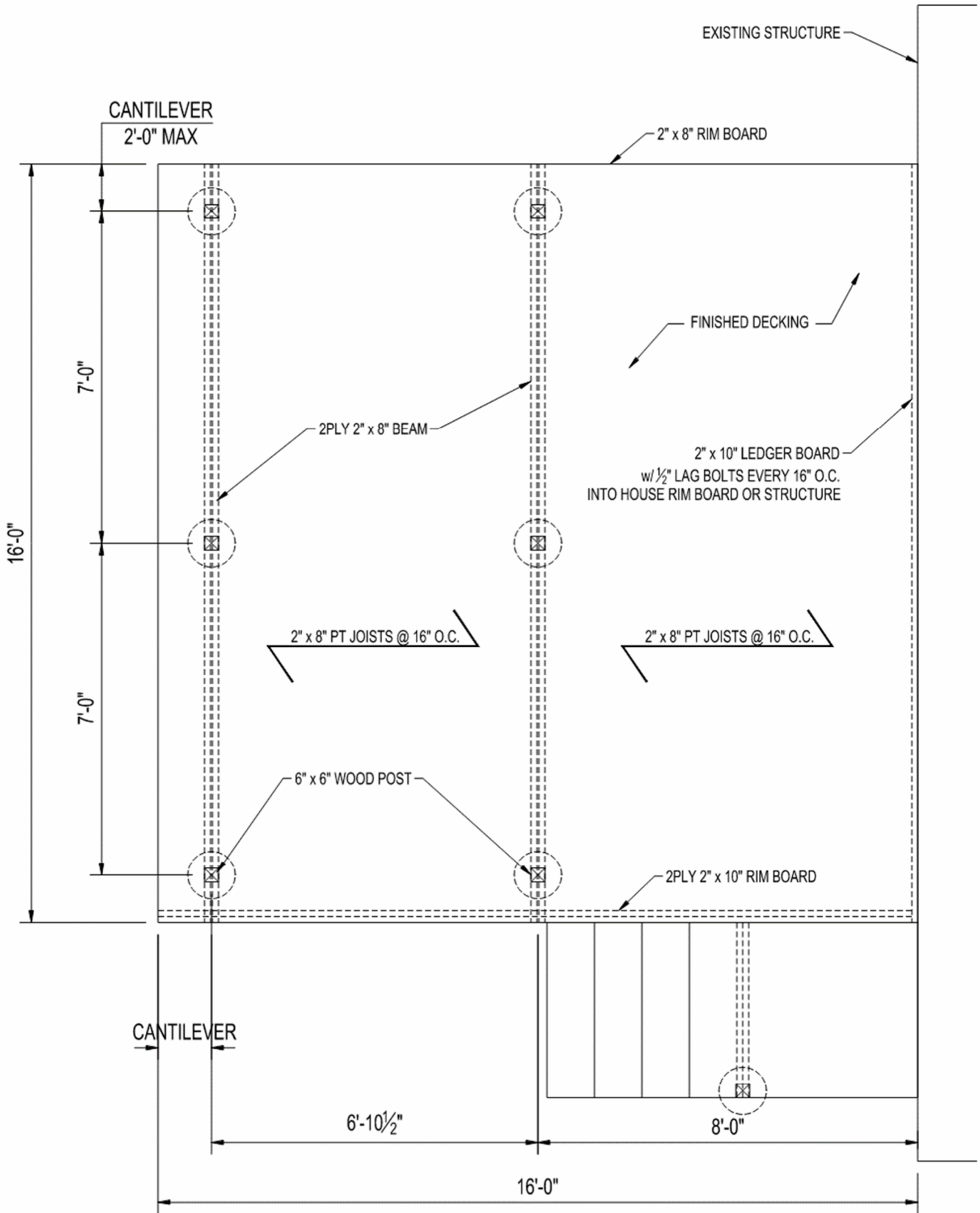

D - UP TO 16'x16' DECK FRAMING PLAN

STEP 4 - WHAT TYPE OF FOOTING AM I GOING TO USE?

Select one from the following Footing Details

Posts set on concrete footings	Footing Detail A
Posts cast into concrete piers	Footing Detail B
Posts anchored to top of concrete piers	Footing Detail C

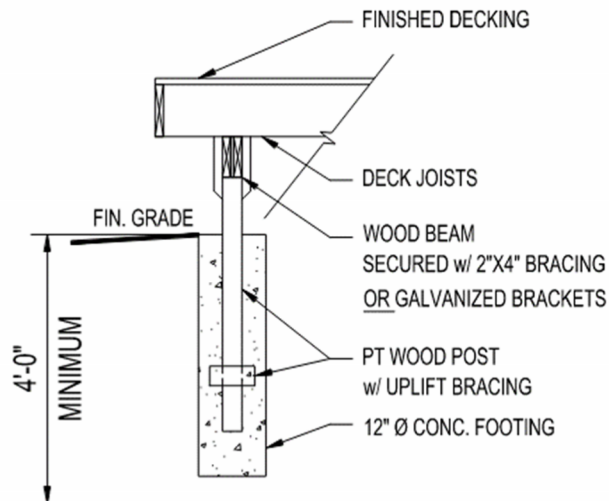
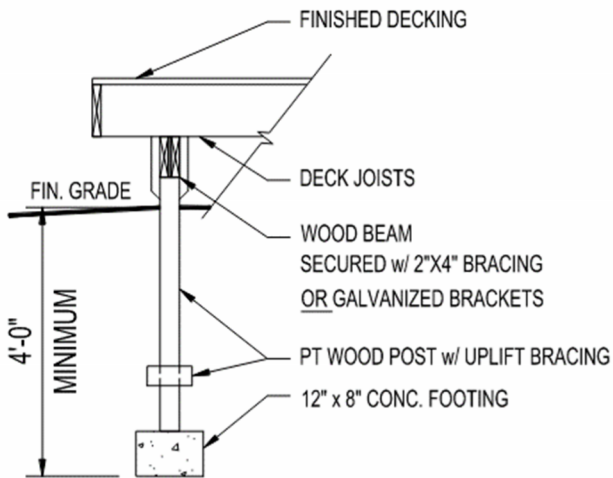

A - FOOTING DETAIL - ON PAD B - FOOTING DETAIL - EMBEDDED

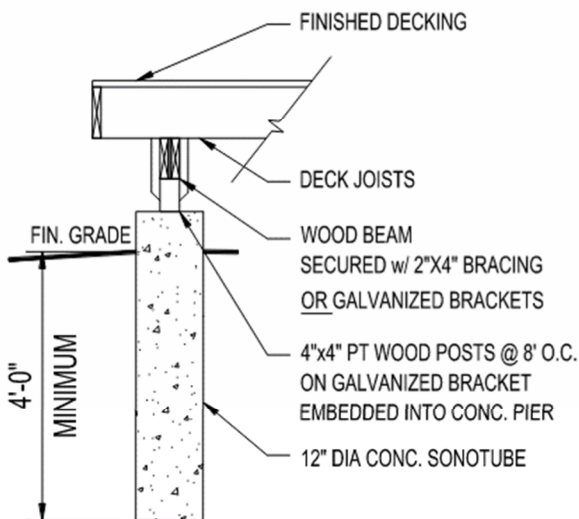

MINIMUM PIER SIZES				
JOIST SPAN	POST SPACING			
	6 0	8 0	10 0	12 0
6'-0"	8"	8"	10"	10"
8'-0"	8"	10"	10"	12"
10'-0"	10"	10"	12"	12"
12'-0"	10"	12"	12"	-
14'-0"	12"	12"	-	-

C - FOOTING DETAIL - ANCHORED @ PIER

STEP 5 – LAYOUT MY DECK

Draw a custom deck layout for your project

Use the above layouts and the tables below to help design your deck project

Be sure to include:

- Overall dimensions of the proposed deck
- Beam sizes
- Joist sizes and spacing
- Pier sizes and spacing
- Post sizes
- Rim board sizes

Tip: Use the example layout in this guide as a reference to see the kind of quality and detail we look for in drawings.

BEAM SIZING TABLE					
JOIST SPAN	PIER SPACING				
	6 0	8 0	10 0	12 0	14 0
6'-0"	2 – 2"x8"	2 – 2"x8"	3 – 2"x8"	3 – 2"x10"	3 – 2"x12"
8'-0"	2 – 2"x8"	2 – 2"x8"	3 – 2"x8"	3 – 2"x10"	3 – 2"x12"
10'-0"	2 – 2"x8"	3 – 2"x8"	3 – 2"x8"	3 – 2"x10"	3 – 2"x12" or 4 – 2"x10"
12'-0"	3 – 2"x8"	3 – 2"x8"	3 – 2"x10"	3 – 2"x10"	3 – 2"x12" or 4 – 2"x10"
14'-0"	3 – 2"x8"	3 – 2"x10"	3 – 2"x10"	3 – 2"x12"	3 – 2"x12" or 4 – 2"x10"

JOIST SIZE & SPAN		
JOIST SIZE	JOIST SPACING	MAXIMUM SPAN
2"x8"	12"	12'-0"
	16"	11'-0"
	24"	10'-0"
2"x10"	12"	14'-0"
	16"	13'-0"
	24"	12'-0"
2"x12"	12"	14'-0"
	16"	14'-0"

Note

Decks may be constructed using either 6"x6" or 4"x4" posts depending on the chosen beam spans. If you are unsure of which size of posts you should be using, please contact a designer.

STAIRS

Stairs must be designed for safe navigation. They must have uniform treads and risers throughout their length and be designed so that the path of travel down the stair is perpendicular to the tread.

DIMENSIONS FOR PRIVATE STAIRS		
	MINIMUM	MAXIMUM
TREADS	9-1/4" (255 mm)	14" (355 mm)
RISERS	4-7/8" (125 mm)	7-7/8" (200 mm)

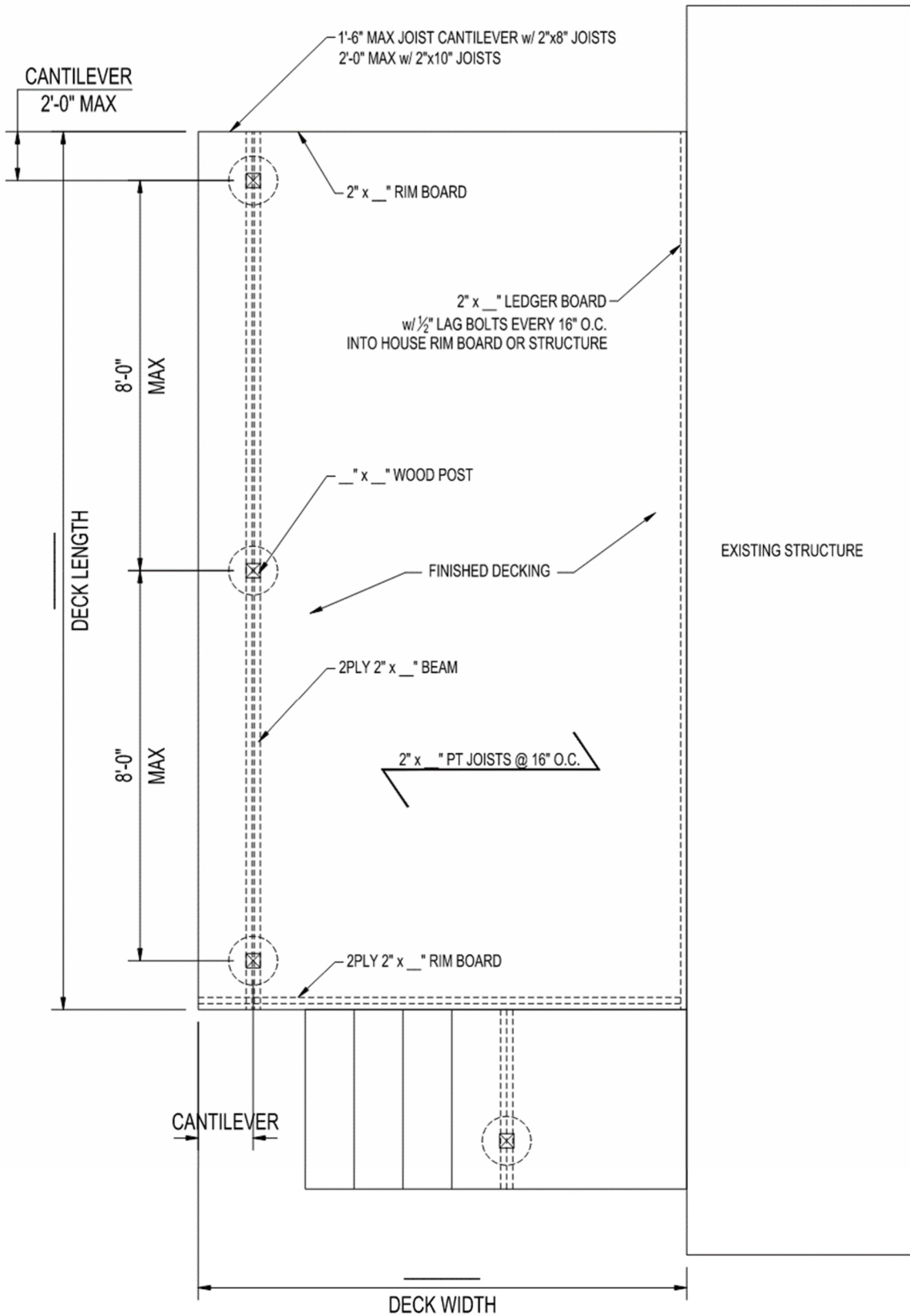

EXAMPLE DECK FRAMING PLAN

CUSTOM DECK LAYOUT

Use this page to draw your own site plan. Call out all required items. All plans must comply with the OBC & City regulations.

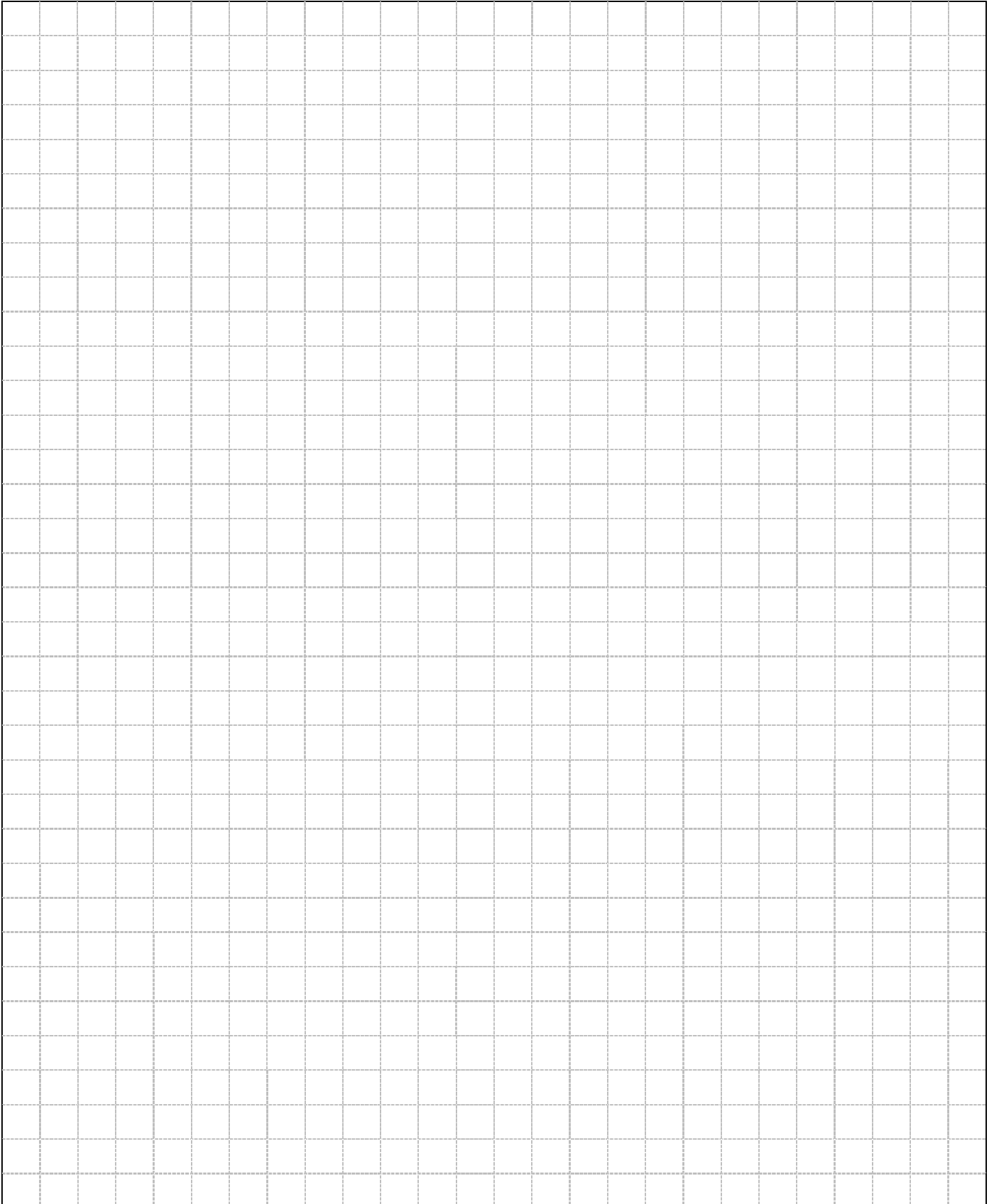

STEP 6 – HOW AM I ATTACHING THE DECK TO THE HOUSE?

Select one from the following Ledger Details

Attached at wood rim joist (siding)	Ledger Detail A
Attached at concrete foundation wall	Ledger Detail B
Attached at wood rim joist (brick)	Ledger Detail C
Attached at block foundation	Ledger Detail D

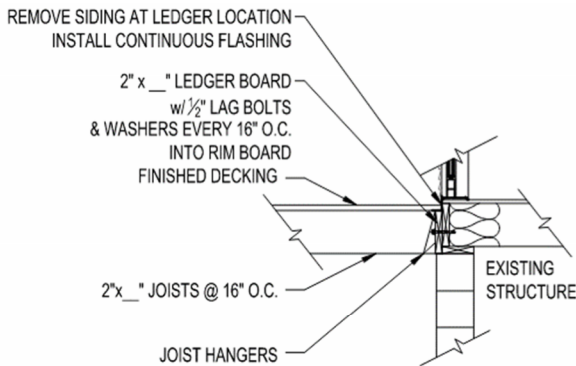

A - LEDGER DETAIL - SIDING

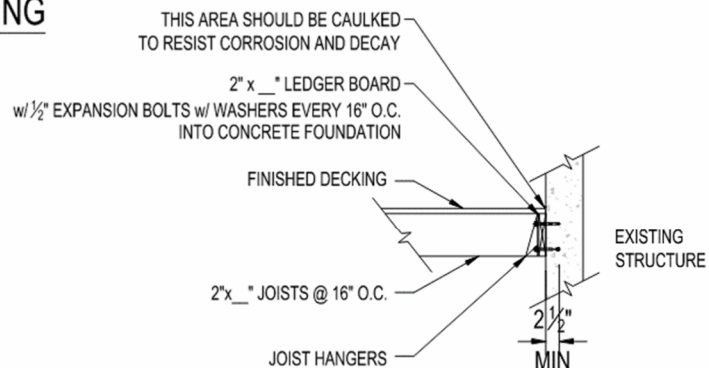

B - LEDGER DETAIL - CONC. FOUNDATION

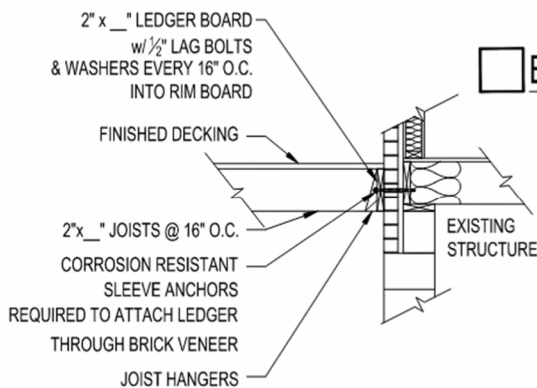

C - LEDGER DETAIL - BRICK

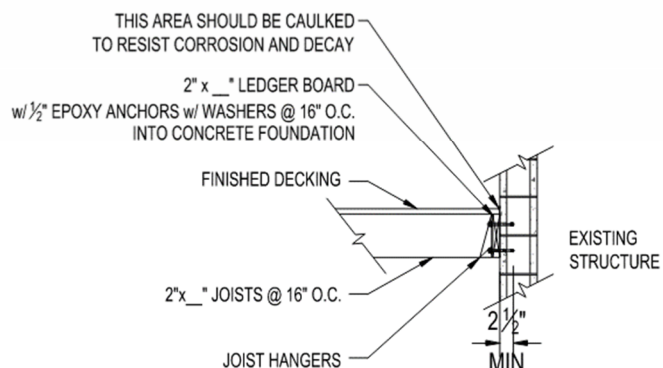

D - LEDGER DETAIL - BLOCK FOUNDATION

STEP 7 – WHAT GUARDS AND RAILINGS ARE REQUIRED?

What is the height of the deck?

From the lowest point of the ground to the top of the deck floor

Up to including 24" (600mm)	No guard required
Over 24" (600mm) up to and including 6'-0" (1800mm)	36" (900mm) high guard required
Over 6'-0" (1800mm)	42" (1070mm) high guard required

Select one from the following Cross Sections

Guard/railing posts are being added to the deck surface	Cross Section A
Guard/railing posts are the same post extended from the footing	Cross Section B

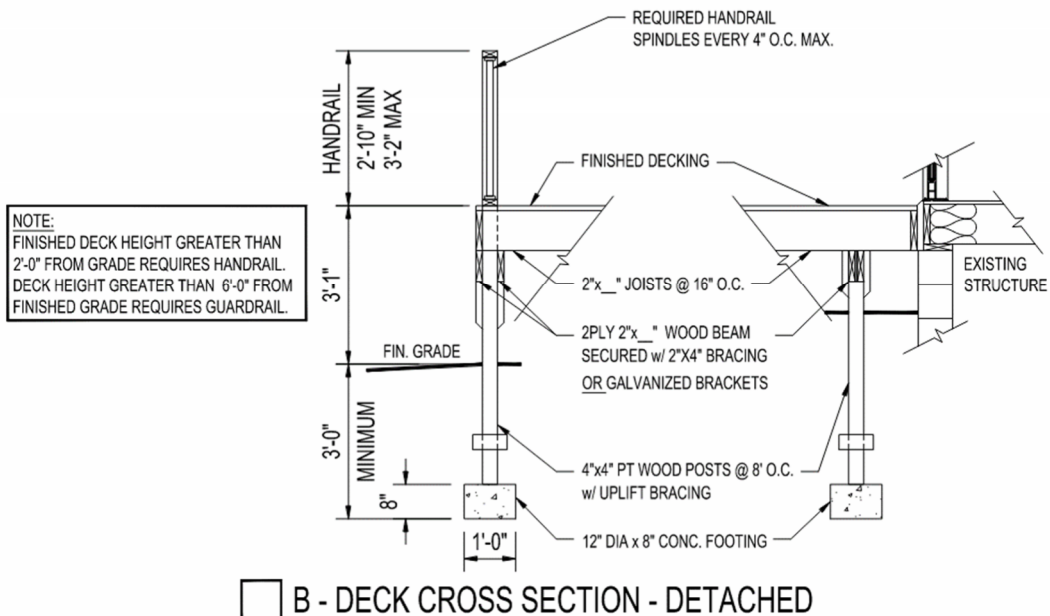
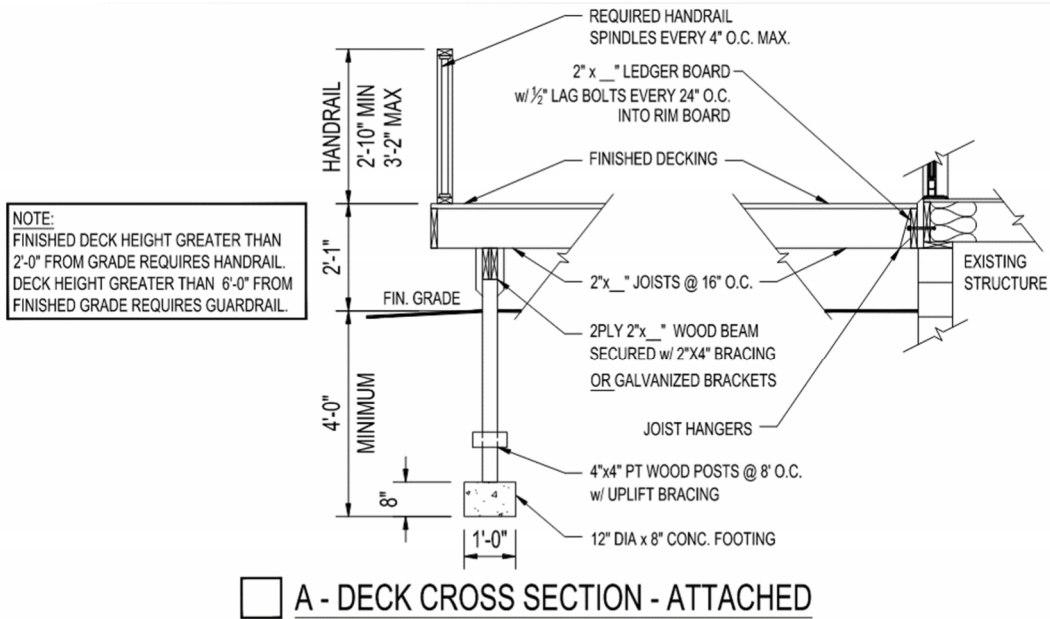

AFTER I GET MY PERMIT WHAT INSPECTIONS ARE REQUIRED?

Inspections are conducted for construction authorized through a building permit that was issued by the City's Building Department. It is the responsibility of the Property Owner or authorized agent of the Property Owner to request building inspections at key stages of construction.

Same day Inspection requests are not available.

A re-inspection fee may be applied for work that is not deemed ready for inspection. To avoid re-inspection fee charges, please contact the dispatcher to cancel before the building inspector attends the site.

Required During All Inspections

- An original set of all issued permit documents from the City (including 1-deck permit, 2-permit plans and 3-any attached documents).
- Safe access to the site during all inspections.

Required Inspections

The following are the required inspections for decks:

1. FOOTING – Before concrete is poured

PRIOR to Construction starting the Inspector will meet with the permit holder on site to:

- Review permit documents with Permit Holder.
- Verify footings are the correct size, placement, and depth per codes.
- Ensure footings are structurally sound, properly formed, and placed on stable soil.

2. FRAMING

During this inspection the inspector will inspect:

- Size and Spacing: Confirm lumber size and spacing align with approved plans and building codes.
- Connections and Nailing: Check secure connections with proper hardware and spacing.
- Anchoring to Foundation: Ensure stable anchoring to the foundation using appropriate fasteners.
- Bracing and Supports: Inspect for adequate bracing and supports per code requirements.

3. FINAL BUILDING

During this inspection the Inspector will review and verify:

- Guardrails and Handrails: Confirm guardrails' height, spacing, and structural integrity. Ensure handrails are installed where necessary.
- Stairs and Landings: Inspect stair for proper tread and riser dimensions, handrail installation, and the presence of landings where required. Ensure safe and code-compliant access to and from the deck.
- Overall Structural Integrity: Conduct a comprehensive review of the entire deck structure to ensure all components are installed correctly, meet code requirements, and are safe for use.

How to Schedule an Inspection

Once a building permit is issued and the project is ready for an inspection by a City building inspector, there are two (2) methods available to request an inspection:

1. REQUEST AN INSPECTION THROUGH THE CLOUDPERMIT SYSTEM

- To book an inspection in the Cloudpermit system, log in to your Cloudpermit account, open the permit that the inspection relates to and follow the prompts to request an inspection.
- Cloudpermit will provide a confirmation for your inspection request
- If the inspection type is not listed as an option under your permit, please call or e-mail dispatch so that we may select the most appropriate inspection type.

2. EMAIL YOUR INSPECTION REQUEST

- A confirmation email will be sent to the requestor confirming the inspection has been booked.
- Send an email to dispatch@citywindsor.ca
- In the subject line of the email, indicate the building permit number and municipal address of the project.
 - In the body of the email, indicate the following:
 - Type of inspection being requested
 - Preferred inspection date time of inspection (a.m. or p.m.) and
 - Site contact name/number (This is the person who will be meeting the inspector on-site.)

ADDITIONAL INFORMATION



Before you dig contact Ontario One Call to locate all buried underground services. For more information go to ontarioonecall.ca or for more information call 1-800-400-2255



Doing electrical work? A notification must be filed with the Electrical Safety Authority. Hiring someone to do electrical work? They must be a Licensed Electrical Contractor. It's the law. For more information go to esasafe.com or call 1-877-372-7233

GLOSSARY OF TERMS

BEAM – means one of the principal horizontal members in a structure to support a floor or ceiling

DECK - means a structure having a floor, open to the sky, and a supporting structure below. It may include perimeter guardrails, fixed seating and vertical visual screening. A patio or terrace is a deck

GRADE – means the average level of proposed or finished ground adjoining a building at all exterior walls

GUARD – means a protective barrier, with or without openings through it, that is around openings in floors or at the open sides of stairs or landings to prevent accidental falls from one level to another

JOIST – means wood members ranged in parallel from wall end to end in a structure to support a floor or ceiling

RIM JOIST – means a framing member that runs perpendicular to the joists and provides lateral support for the ends of the joists

